

PCB. LAYOUT

NOTES:

1. MATERIAL:
 - 1.1 HOUSING: HALOGEN FREE PLASTIC,UL94V-0.
 - 1.2 CONTACT: COPPER ALLOY
- 2.CONTACT:
 - 1:50~100u" NICKEL UNDERPLATING OVERALL.
 - GOLD FLASH PLATING.
3. REFLOW SOLDER CAPABLE TO 260°C PER ACES SPEC.
4. SPEC. PLS. REFER TO PS-50274-XXXX-XXX
5. PACKAGE PLS. REFER TO 86802-XXOX-TRP
6. LOCKING WINDOW:ONE PLACE FOR 2&3 CTKS. TWO PLACES FOR MORE THAN 4 CTKS.
- 7.PART NUMBER

P/N LEGEND

51254-XXX X X-XXX

No Of Contact	XXX	Boss	Color
		001 With Boss	Black
Packing		Plating	
0:Tape & Reel		1:G/F (Lead Free)	
1:Tube			

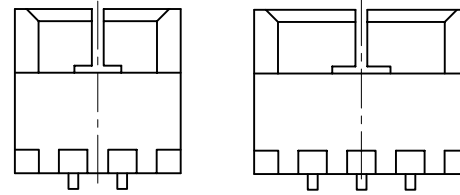
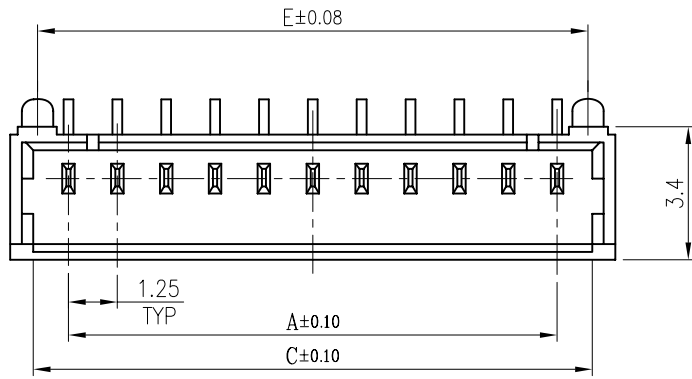

2 PIN

3 PIN

LOCK CONFIGURATION

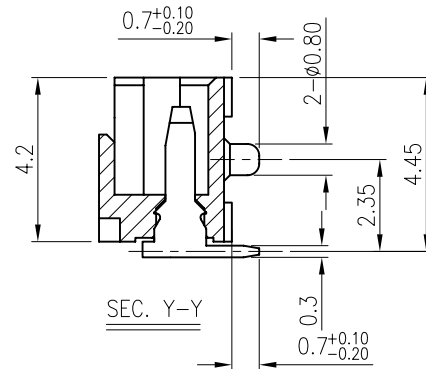
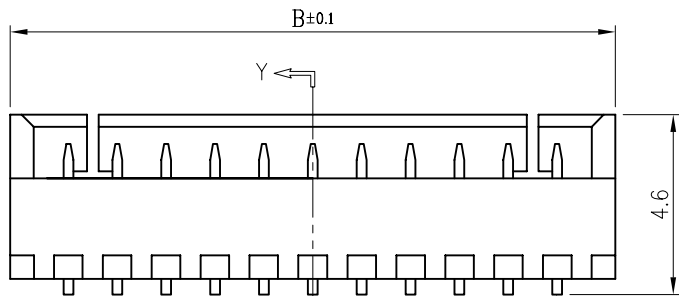

CKT	DIM A	DIM B	DIM C	DIM E
4	3.75	6.73	5.55	5.33

一般公差 TOLERANCES X ±0.5 .XX ±0.15 X ±0.25 .XXX ±0.1 ANGLES ±2°	宏致電子股份有限公司 Aces Electronics Co.,Ltd.	
檢驗尺寸標示 SYMBOLS ⊕ ⊗ INDICATE CLASSIFICATION DIMENSION ⊕ MARK IS CRITICAL DIM. ⊗ MARK IS MAJOR DIM.	品名 (TITLE) 1.25mm WT B Wafer Conn. T/H R/A Type	製圖 (DR) '13/09/25 DAVID 審核 (CHKD) JERRY 核准 (APPD) JASON
圖號 (DWG NO.) 51254-XXXX-XXX	比例 (SCALE) 5:1	單位 (UNITS) mm
表面處理 (FINISH)	張數 (SHEET) 1 OF 1	圖號 (DWG NO.) 51254-XXXX-XXX
圖號 (DWG NO.) 51254-XXXX-XXX	單位 (UNITS) mm	圖號 (DWG NO.) 51254-XXXX-XXX